

Dec. 19, 1939.

J. F. BLACKBURN

2,183,528

LOUDSPEAKER

Filed Aug. 14, 1937

3 Sheets-Sheet 1

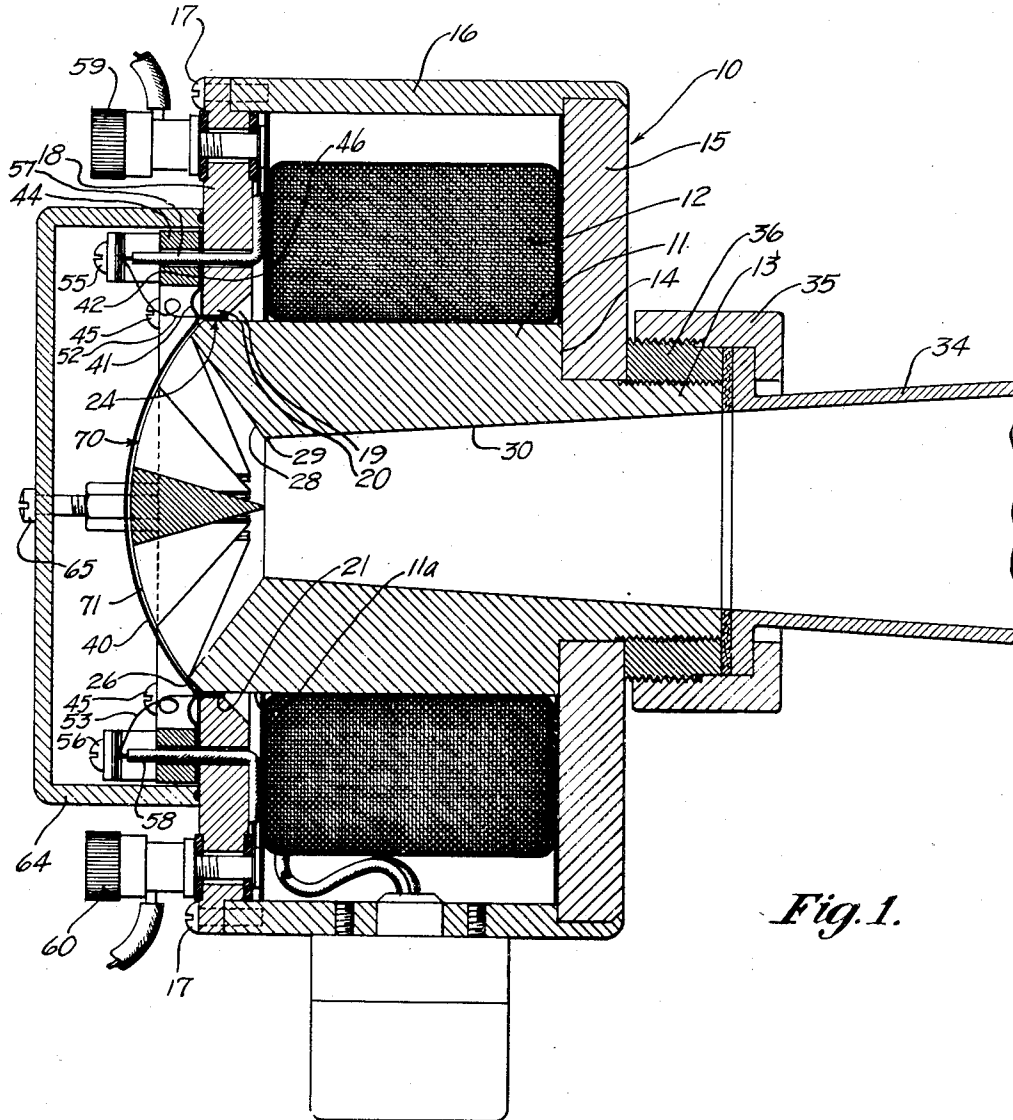

Fig. 1.

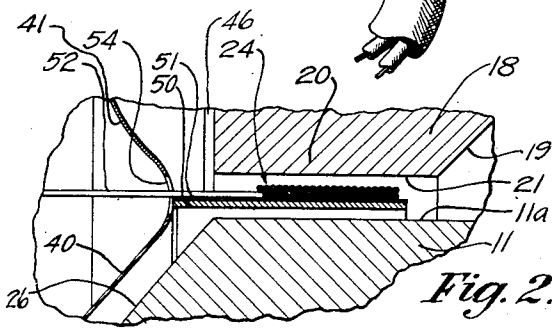

Fig. 2.

Inventor  
John F. Blackburn.

Attorney.

Dec. 19, 1939.

J. F. BLACKBURN

2,183,528

LOUDSPEAKER

Filed Aug. 14, 1937

3 Sheets-Sheet 2

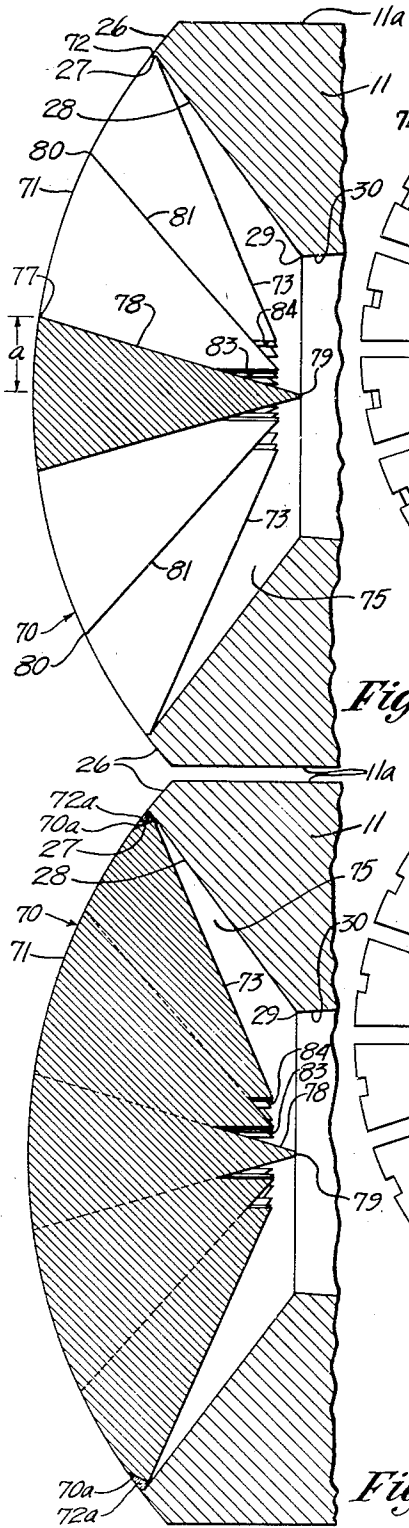
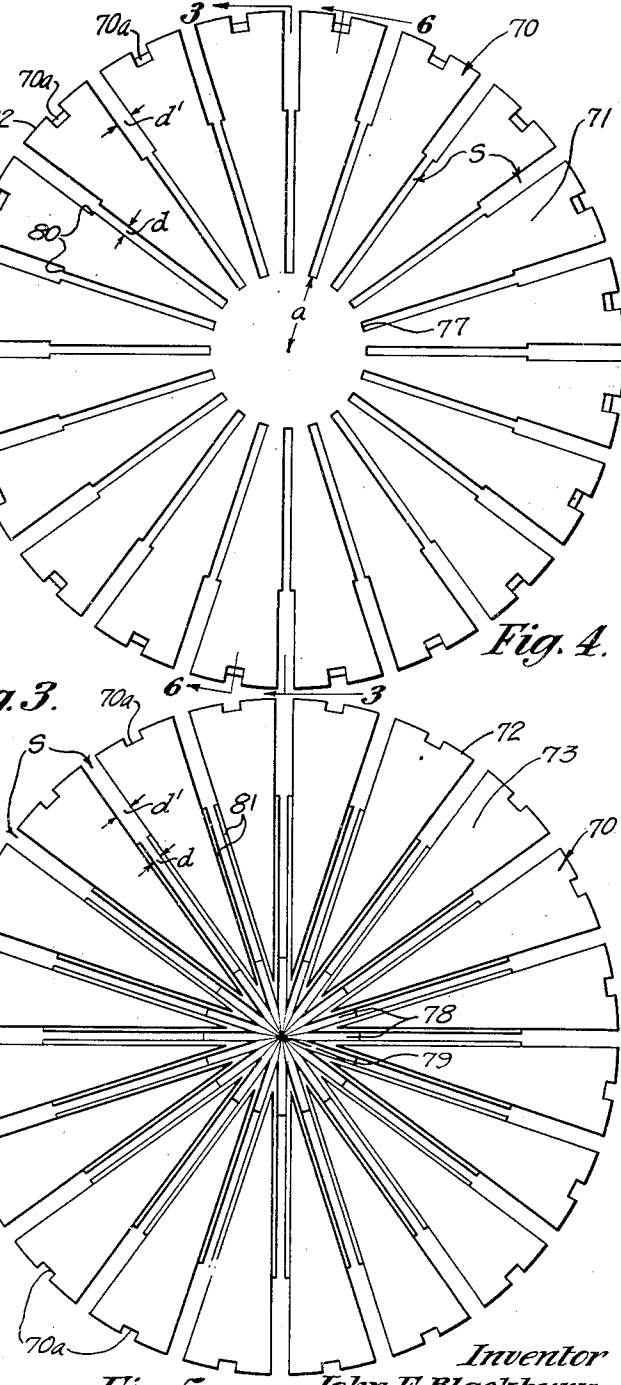

Fig. 3.

Fig. 4.

Fig. 5.

Fig. 6.



Inventor  
John F. Blackburn.

*John F. Blackburn*  
Attorney.

Dec. 19, 1939.

J. F. BLACKBURN

2,183,528

LOUDSPEAKER

Filed Aug. 14, 1937

3 Sheets-Sheet 3

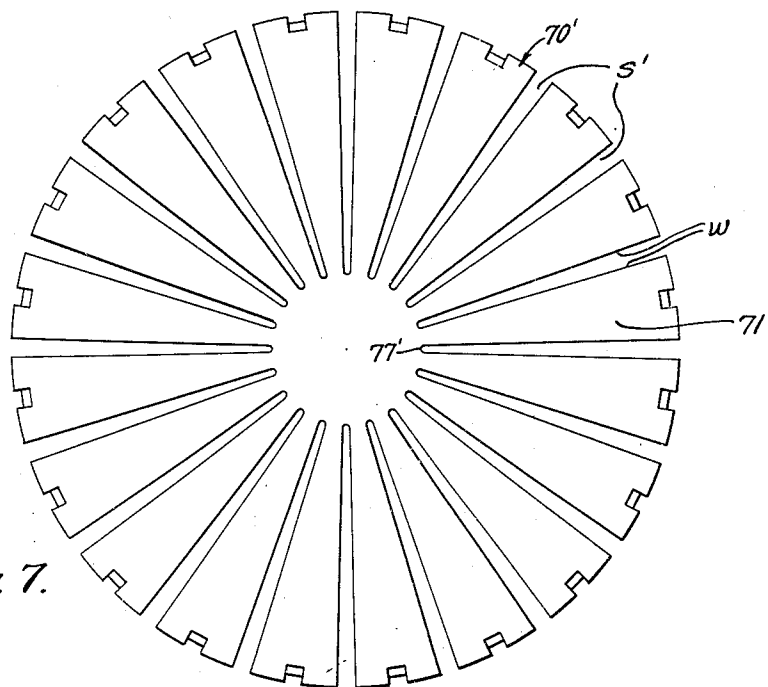

Fig. 7.

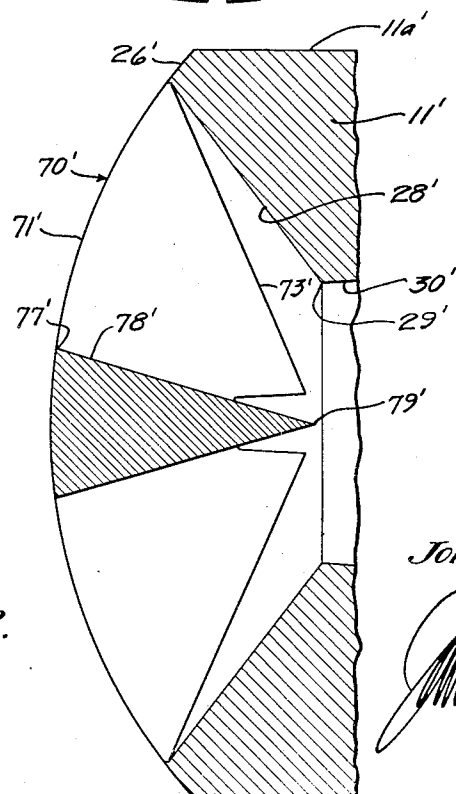

Fig. 8.

Inventor  
John F. Blackburn.

Attorney.

## UNITED STATES PATENT OFFICE

2,183,528

## LOUDSPEAKER

John F. Blackburn, Hollywood, Calif.

Application August 14, 1937, Serial No. 159,063

16 Claims. (Cl. 181—31)

This invention relates generally to loudspeakers, and more particularly to acoustic transformers adapted to be placed between the diaphragm and constricted throat of loudspeakers of the horn type.

A primary general object of the invention may be stated to be the provision of an improved horn type loudspeaker having a uniform level of response over a frequency range of substantially 200 to 10,000 cycles and an acoustic efficiency as high as at least 50%.

It is a fundamental requirement in a horn loudspeaker that to obtain high efficiency of energy transfer between diaphragm and air, the acoustic impedance of the air or medium in front of the diaphragm must be matched with the mechanical impedance of the diaphragm. An impedance matching device or acoustic transformer, which properly constricts the cross-sectional area of the sound channel between the diaphragms and the throat of the horn, is ordinarily employed for this purpose. The diaphragm is loaded by this acoustic transformer by a loading factor which may be taken as the ratio of the effective diaphragm area to the total cross-sectional area of the constricted sound channel, and this loading factor is made such as to damp out resonant action of the diaphragm at certain frequencies.

The loading of the diaphragm should be as uniform as possible over its entire area, and it is one purpose of the present invention to provide a loudspeaker in which the acoustic loading is exceptionally uniform over the area of the diaphragm.

The dimensions of the sound channel between diaphragm and horn throat must be such that waves of any frequency of interest emanating simultaneously from different points of the diaphragm will not arrive at any point in the throat 180° out of phase, since otherwise destructive interference between such waves will occur. The desideratum is that waves originating from all points along a radial element or sector of the diaphragm shall form a wave front of the desirable shape at the throat of the horn. It has been considered that to avoid destructive interference at the throat between waves originating at the center and at the outer edge of the diaphragm, individual sound channels to the throat, of substantially equal lengths, must be provided for waves originating near the center of the diaphragm and waves originating near its outer edge. As a result of this theory, acoustic transformers have been built in which there are

formed a plurality of annular, concentric sound passages, all of substantially equal length from diaphragm to throat. An acoustic transformer in this form is feasible and performs well, though it is difficult and expensive to construct.

It is accordingly a further object of the present invention to provide an acoustic transformer of such design as will avoid material destructive interference between waves arriving at the throat from all points on the diaphragm, and which is at the same time relatively simple and inexpensive to construct, as well as exceptionally rugged in service.

I have found that the performance of the aforementioned concentric channel construction, designed to provide concentric sound channels of exactly equal length from successive annular zones of the diaphragm to the throat, is surpassed in uniformity of response over a frequency range extending as high as 10,000 cycles, by a design in which the sound channels are disposed radially of the diaphragm, so that each sound channel subtends a sector of the diaphragm. It will be evident that in such a construction (radial sound channels), each sound channel passes waves originating along a continuous radial elemental area of the diaphragm. A wave front emanating from each such radial elemental area of the diaphragm accordingly advances, without further subdivision, through the corresponding radial sound channel to the throat of the horn, arriving at that plane probably as an approximately spherically fronted wave. It will be evident that the waves advancing through the entire set of radial sound channels are exactly similar in form and intensity, and these waves upon emerging from the outgoing ends of the channels unite along radial planes to form a continuous wave front at the throat of the horn. No destructive interference is encountered provided the maximum distance from any point of the diaphragm to the entrance opening of the nearest radial sound channel is made no greater than a quarter wave length of the highest frequency of interest. A loudspeaker provided with an acoustic transformer in accordance with the present invention shows a highly uniform level of response from 200 to 10,000 cycles, falling off not more than 2 db. from its maximum output at any point within that frequency range.

The invention will be best understood by referring now to the following detailed description of a present preferred embodiment thereof, reference for this purpose being had to the accompanying drawings, in which:

Fig. 1 is a full scale longitudinal medial section through a loudspeaker in accordance with the present invention;

Fig. 2 is an enlarged detail taken from Fig. 1;

Fig. 3 is an enlarged detail taken from Fig. 1, being a cross-sectional view of the acoustic transformer as indicated by section lines 3—3 on Fig. 4;

Fig. 4 is a rear elevation of the acoustic transformer element;

Fig. 5 is a front elevation of the acoustic transformer element;

Fig. 6 is a cross-section taken as indicated by line 6—6 on Fig. 4;

Fig. 7 is a rear face view of a modification; and

Fig. 8 is a section on line 8—8 of Fig. 7.

In the drawings the loudspeaker, generally denoted by reference numeral 10, is provided with a central hollow annular core or pole piece 11, surrounded by a suitable winding 12. Pole piece 11 is provided at its forward end with a reduced externally threaded extension 13, and mounted on extension 13, against shoulder 14, is an annular, magnetic plate or forward casing member 15. Mounted on the periphery of annular member 15 is a cylindrical magnetic casing member 16 which encloses winding 12, and secured, as by screws 17, to the rearward edge of casing member 16 is an annular outer pole piece member 18. The inner edge of pole piece 18 is tapered, as at 19, to form a reduced pole tip 20 defined at its inner end by an annular cylindrical surface 21 spaced by approximately .031" from the outer cylindrical surface 11a at the rearward end of pole piece 11 (see Fig. 2). The voice coil 24, later to be described in more detail, is placed in the gap between pole tip 20 and pole piece surface 11a. Back of the rearward plane of pole tip 20, pole piece 11 is formed with an annular spherical surface 26, which is connected by a short countersink 27 with a conical inwardly disposed surface 28, the latter joining at 29 with a central bore or sound channel 30 having an exponentially increasing cross-sectional area. The juncture 29 of surface 28 and bore 30 forms the constricted throat of the horn.

A suitable outer horn 34 is indicated as connected to threaded pole piece extension 13 by means of nut 35 and adapter ring 36.

The diaphragm, which is preferably of the piston type, comprises a dome shaped portion 40, approximately 2 mils in thickness and formed typically of duralumin, of the same diameter and positioned immediately to the rear of pole piece member 11, the dome shaped member being formed at its periphery with a trough-shaped compliance 41 and an outer flange 42 adapted to be clamped between the rearward surface of pole piece 18 and a clamp ring 44 secured to pole piece 18 as by screws 45, a fabric ring 46 being placed between flange 42 and the pole piece. The clearance between diaphragm dome 40 and the rearwardly facing annular surface 26 on pole piece 11 is of the order of .030".

Secured to the diaphragm, at the margin of its dome shaped portion 40, is a forwardly projecting paper tube 50, which is wrapped with a layer of silk 51 and then with the aforementioned voice coil 24, tube 50 and coil 24 projecting into the space between pole tip 20 and the rearward end of pole piece 11, as clearly indicated in the drawings. The terminal leads 52 and 53 of voice coil 24 pass rearwardly through apertures 54 in the diaphragm and go to terminal posts 55 and 56, respectively, mounted on ring 44. Terminal

posts 55 and 56 are interconnected by conductors 57 and 58 with external binding posts 59 and 60, respectively, all as clearly indicated in Fig. 1. The rearward side of the diaphragm, together with clamp ring 44 and terminal posts 55 and 56, are enclosed by a cap 64 engaging the rearward surface of pole piece 18 and secured in place by any suitable means, as by screws indicated at 65 and which will be understood to have threaded connection with clamp ring 44.

The acoustic loading transformer of the present invention is designated generally by numeral 70. This member 70, which for ease of cutting is preferably formed of brass, has a spherical rearward surface 71, of the same radius of curvature as diaphragm dome 40, and is mounted in the rearward end of pole piece member 11, having a peripheral edge 72 received within countersink 27 in member 11 in such a manner that surface 71 is flush with pole piece surface 26, surfaces 71 and 26 being concentric and of the same radius of curvature. Member 70 is secured in position in the end of pole piece 11 by soldering within notches 70a cut in edge 72, as indicated at 72a (Fig. 6).

The forwardly facing surface 73 of member 70 is conical in shape, being formed at a greater angle with reference to the central axis of the device than the angle between conical pole piece surface 28 and said axis, so as to leave an annular air space 75 between surfaces 73 and 28 which increases in cross-sectional area toward the throat of the horn. In the present illustrative embodiment, surface 28 is disposed at an angle of approximately 53° to the axis of the throat, while surface 73 is disposed at an angle of approximately 66° to said throat. The angle of surface 28 is determined chiefly by magnetic considerations, since if this angle is too small, there is danger of pole tip saturation, though if the angle is made too great there is a choking effect due to the sound waves emanating from the acoustic transformer striking surface 28 too nearly at right angles. An angle within a range of substantially 45° to 60° is appropriate for surface 28, being in the present embodiment approximately 53°, as mentioned above.

The sound ducts or channels in transformer 70 are in the form of equally spaced radial slits *s*, which in the embodiment of the invention illustrated in Figs. 1-6 are defined by parallel side walls. The theoretical cross-sectional slit shape for uniform diaphragm loading is triangular or sector shaped, with the apex of the triangle or sector at the center of the device. The parallel-sided cross-sectional slit shape of the device of Figs. 1-6 is an approximation to a triangular or sector-shaped slit, and may be preferred since it requires only stock size milling cutters for production.

To produce the slits *s* in the device, a plurality of radial, equally spaced cuts are made, extending inwardly at the rear face of the device to a depth determined by the requirement that the dimension *a* from the center of surface 71 to the bottom of the cut shall be no greater than a quarter wave length of the highest frequency of interest. The slits are thus cut, preferably with a milling cutter, with a thickness dimension *d* to a depth along face 71 such that dimension *a* is a quarter wave length or less of the highest frequency desired to be reproduced without substantial attenuation, the intersection of the bottom of the cut with rear face 71 being indicated by numeral 77. The bottom 78 of the cut or slit is straight and intersects

the apex 79 of the cone determined by the front conical face 73 of the device. It will be noted that apex 79 lies in the plane of the most constricted point of the horn throat.

The deep cuts as just described, defined at the bottom by points 77 and 79, are next widened in their outer portions to a depth along face 71 as indicated by numeral 80, the bottom of the cut again being straight and intersecting apex 79 at the front of the device. The width of these last mentioned cuts may be of a dimension  $d'$  equal to about twice dimension  $d$ . The depth of the second cut, measured along face 71, is preferably about 40% of the depth of the first or deep cut. It will be evident that the second cut is defined at the bottom by shoulders as indicated at 81. The notches appearing at 83 and 84 are caused by intersection of adjacent cuts near the central axis of the device.

Certain theoretical considerations involved in the design of a unit in accordance with the present invention will now be given. The loading factor, which may be defined as the ratio of effective diaphragm area to total cross-sectional area of sound passages in the acoustic transformer, as measured on its rearward face 71, should be substantially seven or greater for best performance in the instance of the present embodiment of the invention, being 7.1 in the illustrative embodiment, though this may vary with variations in other design features. The area of the constricted throat (taken at plane 29) is preferably equal to the cross-sectional area of the sound passages, and the diameter of the throat is therefore the effective diameter of the diaphragm divided by the square root of the loading factor, or in other words is equal to

$$\frac{d}{\sqrt{7.1}}$$

where  $d$  is the effective diameter of the diaphragm (diameter inside the voice coil).

To avoid destructive interference within each slit  $s$  between waves originating at different points on the diaphragm, it is necessary that no point on the diaphragm dome be more distant from the entrance opening of the nearest slit than a quarter wave length of the highest frequency of interest. It was stated previously that dimension  $a$  (distance between bottom of slit and center of surface 71) should be no greater than a quarter wave length of the highest frequency of interest, though, as will be evident, the actual dimension which must be held within the limit stated is the distance between the bottom of the slit at surface 71 and the center of the diaphragm. However, since the center of surface 71 and the center of the diaphragm are separated by a distance of no more than approximately .030", sufficient accuracy is achieved if dimension  $a$  be held within a quarter wave length. Similarly, all points at the outer margin of the effective diaphragm area must be separated by no more than a quarter wave length of the highest frequency of interest from the nearest slit entrance opening. In general, the outer ends of the slits should be as close to the edge of the effective diaphragm area as possible, but a limitation is established by the requirement that annular pole piece surface 26 must be sufficiently wide to avoid excessive pole tip saturation. On the other hand, if surface 26 is too wide, excessive losses are introduced by reason of "blow-by" around the outside of pole piece 11.

Having determined the width of annular surface 26 as a suitable compromise between these last mentioned factors, the number of slits employed is made such that the outer ends of the entrance openings of the slits will be no more distant than a quarter wave length of the highest frequency of interest from any point on the outer margin of the effective area of the diaphragm, which is the area of the diaphragm inside the voice coil. A sufficiently close approximation is made if no point on the pole piece rim, that is, on surface 26, is more distant from the outer ends of the slits than a quarter wave length of the highest frequency of interest. The total cross-sectional area of the entire set of slits at surface 71 is obtained as the quotient of effective diaphragm area and the loading factor. In the present design, this total slit area, which may be called  $A$ , is divided between twenty slits, so that each slit has an area at surface 71 of

$$\frac{A''}{20}$$

This individual slit area at surface 71 is distributed between an inner slit portion of width  $d$ , and an outer slit portion of a width equal to  $2d$  (dimension  $d'$ ), the length or depth of the widened slit portion being about 40% of the depth of the entire slit. This slit shape affords a sufficiently accurate approximation to the theoretical triangular slit which has its apex at the center or central axis of the device (more nearly achieved in the form of Figs. 7 and 8), and effects comparatively uniform loading of all points on the diaphragm sector surrounding or controlled by each slit. The condition necessary to be satisfied is that the loading factor, calculated for successive concentric zones, shall not vary too widely from the mean value. It will be evident that the greater the number of slits used, the better is this condition satisfied; in the present embodiment, twenty slits of the shape and size stated has been found proper.

The illustrative embodiment of the invention as now described shows an acoustic efficiency of approximately 50% for frequencies of from 200 to 10,000 cycles, no appreciable attenuation of response occurring at either the high or low end of the indicated frequency range, while at no point within that range does the response level fall off more than 2 db. The acoustic transformer of the present invention not only performs in a superior manner, but is relatively simple and inexpensive to manufacture, as well as being of very rugged construction.

Figs. 7 and 8 show a modification in which the theoretical triangular or sector-shaped slit is more nearly achieved, yielding even more uniform loading of the diaphragm. The device of Figs. 7 and 8, generally indicated at 70', thus has slits  $s'$ , the sides  $w$  of which are defined by converging planes spaced just slightly outside of true radial planes intersecting the central axis. The bottom 78' of each slit again terminates at a point 77' on face 71' which is located a quarter wave length or less of the highest frequency of interest from the center of the device, and terminates at the front surface 73' of the device at apex point 79'. The rounded shape at the bottom of the slit is produced by the somewhat blunt forward edge of the milling cutter used in cutting the slits. As previously stated, the ideal cross-sectional slit shape for uniform loading is a true radial sector, with

its apex on the axis. The slit *s'* of the form of the invention shown in Figs. 7 and 8 terminates short of the central axis, but this is compensated by making the slit slightly wider than a true sector shape, the planes defining the side wall surfaces of each slit thus converging toward a line parallel to but located a short distance beyond the central axis of the device. The slits are cut by a milling cutter having correspondingly converging sides, and it will be evident that the slits accordingly diverge in width, measured along lines parallel to the central axis of the device, though they are of constant width measured along lines parallel to the bottoms of the slits.

The two forms of the invention herein described are illustrative of close approximations of the ideal radial sector-shape, either of which may easily be cut on a milling machine. It will of course be understood that a slit of the described ideal radial sector-shape, as well as other approximations thereof, forms a part of the present invention and is included within the scope of the claims.

The invention has now been described as embodied in a loudspeaker, though it is to be understood that the specific illustrative application to loudspeakers is but one of its practical applications, and that the mechano-acoustic transducer of the present invention is applicable as well to various other acoustic devices such as phonograph reproducers, stethoscopes, microphones, sound ranging devices, etc.

It will further be understood that the drawings and description are to be taken generally as illustrative of rather than restrictive on the broad invention, and that various other changes in design, structure and arrangement may be made without departing from the spirit and scope of the invention or of the appended claims.

I claim:

1. An acoustic transformer for use within a sound translating device having a dome shaped piston diaphragm and a converging sound channel leading from the concave side of said diaphragm to a constricted horn throat, comprising a device formed with a convex rear surface of substantially the same radius of curvature as said diaphragm mounted within said sound channel concentric with and closely adjacent to the concave surface of said diaphragm, the forward surface of said device sloping inwardly toward a central axis passing through the center of the diaphragm, and said device having a plurality of substantially radial sound duct slits disposed substantially at right angles to the diaphragm.

2. An acoustic transformer for use within a sound translating device having a dome shaped piston diaphragm and a converging sound channel leading from the concave side of said diaphragm to a constricted horn throat, comprising a device formed with a convex rear surface of substantially the same radius of curvature as said diaphragm mounted within said sound channel concentric with and closely adjacent to the concave surface of said diaphragm, the forward surface of said device being conical and converging forwardly toward an apex on a central axis passing through the centers of the diaphragm and throat, and said device having a plurality of substantially radial sound duct slits disposed substantially at right angles to the diaphragm.

3. An acoustic transformer for use within a sound translating device having a dome shaped piston diaphragm and a converging sound chan-

nel leading from the concave side of said diaphragm to a constricted horn throat, comprising a device formed with a convex rear surface of substantially the same radius of curvature as said diaphragm mounted within said sound channel concentric with and closely adjacent to the concave surface of said diaphragm, the forward surface of said device sloping inwardly toward a central axis passing through the centers of the diaphragm and throat, and said device having a plurality of substantially radial sound duct slits disposed substantially at right angles to the diaphragm, each of said slits comprising a parallel-sided inner slit portion and a wider parallel-sided outer slit portion.

4. An acoustic transformer for use within a sound translating device having a dome shaped piston diaphragm and a converging sound channel leading from the concave side of said diaphragm to a constricted horn throat, comprising a device formed with a convex rear surface of substantially the same radius of curvature as said diaphragm mounted within said sound channel concentric with and closely adjacent to the concave surface of said diaphragm, the forward surface of said device sloping inwardly toward a central axis passing through the centers of the diaphragm and throat, and said device having a plurality of substantially radial sound duct slits disposed substantially at right angles to the diaphragm, the depth of each of said slits at the rear convex surface of the device being such that the slit terminates short of the central axis of the device but is located no farther from the center of the diaphragm than substantially one quarter wave length of the highest frequency of interest, and the bottom of said slit sloping inwardly to approach said central axis at the forward side of the device.

5. An acoustic transformer for use within a sound translating device having a dome shaped piston diaphragm and a converging sound channel leading from the concave side of said diaphragm to a constricted horn throat, comprising a device formed with a convex rear surface of substantially the same radius of curvature as said diaphragm mounted within said sound channel concentric with and closely adjacent to the concave surface of said diaphragm, the forward surface of said device being conical and converging forwardly toward an apex on a central axis passing through the centers of the diaphragm and throat, and said device having a plurality of substantially radial sound duct slits disposed substantially at right angles to the diaphragm, the depth of each of said slits at the rear convex surface of the device being such that the slit terminates short of the central axis of the device but is located no farther from the center of the diaphragm than substantially one quarter wave length of the highest frequency of interest, and the bottom of said slit sloping inwardly to approach said central axis at the forward side of the device.

6. An acoustic transformer comprising a device having a rearward surface convex about a central axis and adapted to be positioned in close spaced relation to the concave surface of a dome shaped diaphragm, and having a conical forward surface tapering forwardly toward said axis, a plurality of equally spaced radial slits in said device extending radially with reference to said axis, the depth of each of said slits at the rear convex surface of the device being such that the slit terminates short of the central axis of the device



but is located no farther from the center of the diaphragm than substantially one quarter wave length of the highest frequency of interest, and the bottoms of said slits sloping inwardly to define a cone having its apex on said axis.

7. An acoustic transformer comprising a device having a rearward surface convex about a central axis and adapted to be positioned in close spaced relation to the concave surface of a dome shaped diaphragm, and having a conical forward surface tapering forwardly toward said axis, a plurality of equally spaced radial slits in said device extending radially with reference to said axis, the depth of each of said slits at the rear convex surface of the device being such that the slit terminates short of the central axis of the device but is located no farther from the center of the diaphragm than substantially one quarter wave length of the highest frequency of interest, and the bottoms of said slits sloping inwardly to define a cone having its apex on said axis, each of said slits being defined by parallel side surfaces, and approximately the outer 40% of each slit being of a width approximately twice that of the balance of the slit.

8. An acoustic transformer for use in association with a dome shaped piston diaphragm, comprising a body positioned adjacent the concave surface of said diaphragm and providing a plurality of equally spaced sound duct slits extending forwardly from said diaphragm, said slits having entrance openings adjacent said diaphragm which extend in directions radial of said diaphragm, the total cross-sectional area of said radial slits at said entrance openings being no greater than one seventh of the effective area of said diaphragm.

9. In a sound translating device comprising a diaphragm, walls forming a sound chamber converging in a forward direction along the central axis of said diaphragm, said walls leading from a position adjacent said diaphragm to an axial constricted throat: sound chamber constricting means positioned in said chamber closely adjacent and substantially parallel to said diaphragm and substantially filling the sound chamber at the diaphragm end of said chamber, the forward side of said means converging toward said axis with greater steepness than the convergence of said chamber walls, whereby an annular space of increasing cross-sectional area in a forward direction is formed between the forward side of said means and said converging walls, and a plurality of substantially radially disposed sound duct slits formed in said constricting means.

10. An acoustic transformer for a sound translating device that has a diaphragm and a constricted horn throat spaced from said diaphragm, comprising: a body between said diaphragm and throat having a rearward surface closely spaced to said diaphragm and formed with a plurality of sound duct slots leading therethrough between said rearward surface of said body and said throat, and distributed about and extending outwardly from the axis defined by the centers of the diaphragm and throat.

11. An acoustic transformer for a sound translating device that has a diaphragm, a constricted horn throat coaxial with and spaced from said diaphragm, and a sound channel between said diaphragm and said horn throat, comprising: a space constricting device positioned in said sound channel adjacent said diaphragm and extending toward said throat defining a plurality of sound

ducts leading longitudinally of said channel, said ducts having elongated entrance openings adjacent said diaphragm which extend in directions radial of the axis defined by the centers of the diaphragm and throat.

12. An acoustic transformer for a sound translating device that has a diaphragm, a constricted horn throat coaxial with and spaced from said diaphragm, and a sound channel between said diaphragm and said horn throat, comprising: a space constricting device positioned in said sound channel adjacent said diaphragm comprising a body formed with a plurality of sound duct slots extending longitudinally of the sound channel and substantially radially of the axis defined by the centers of the diaphragm and throat.

13. An acoustic transformer for a sound translating device that has a diaphragm, a constricted horn throat coaxial with and spaced from said diaphragm, and a sound channel between said diaphragm and said horn throat, comprising: a space constricting device positioned in said sound channel adjacent said diaphragm comprising a body formed with a plurality of sound duct slots extending longitudinally of the sound channel, said slots being symmetrically disposed about the axis defined by the centers of the diaphragm and throat, and the sides of the slot extending outwardly from said axis.

14. An acoustic transformer for a sound translating device that has a dome shaped piston diaphragm, a constricted horn throat coaxial with and spaced from the concave surface of said diaphragm, and a sound channel between said diaphragm and said horn throat, comprising: a space constricting device positioned in said sound channel comprising a body having a convex surface adjacent and closely spaced to said concave surface of said diaphragm, said body having a plurality of sound duct slots extending forwardly therethrough from said convex surface toward said throat, said slots having elongated entrance apertures opening through said convex surface adjacent said diaphragm, the inner and outer ends of said apertures being located at different distances from the axis defined by the centers of the diaphragm and throat.

15. An acoustic transformer for a sound translating device that has a dome shaped piston diaphragm, a constricted horn throat coaxial with and spaced from the concave surface of said diaphragm, and a sound channel between said diaphragm and said horn throat, comprising: a space constricting device positioned in said sound channel comprising a body having a convex surface adjacent and closely spaced to said concave surface of said diaphragm, said body having a plurality of sound duct slots extending forwardly therethrough from said convex surface toward said throat, said slots having elongated entrance apertures opening through said convex surface adjacent said diaphragm, the inner and outer ends of said apertures being located at different distances from the axis defined by the centers of the diaphragm and throat, and said entrance openings being so disposed that no point on the effective area of the diaphragm is spaced more distant from the nearest entrance opening than one quarter wave length of the highest frequency desired to be reproduced without attenuation.

16. An acoustic transformer for a sound translating device that has a dome shaped piston diaphragm, a constricted horn throat coaxial with and spaced from the concave surface of said diaphragm, and a sound channel between said



diaphragm and said horn throat, comprising: a space constricting device positioned in said sound channel comprising a body having a convex surface adjacent and closely spaced to said concave surface of said diaphragm, said body having a plurality of sound duct slots extending forwardly

therethrough from said convex surface toward said throat, said slots extending substantially radially of the axis defined by the centers of the diaphragm and throat and being distributed uniformly about said axis.

JOHN F. BLACKBURN.